



UNIVERSITY OF MINES AND TECHNOLOGY, TARKWA
SECOND SEMESTER EXAMINATIONS, MAY 2018

COURSE NO: GL 472 Unihubgh.com
COURSE NAME: FOUNDATION ENGINEERING
CLASS: GL IV **TIME:** 3 HOURS

Name: _____ Index Number: _____

SECTION A: ANSWER ALL QUESTIONS .Each question carries 2.5 marks

1. The bearing capacity is the power of foundation soil to hold the forces from the superstructure without shear failure or
 - a. Settlement
 - b. Structural damage
 - c. Excessive settlement
 - d. Swell
2. The net ultimate bearing capacity is the maximum.....a foundation soil can withstand without undergoing shear failure
 - a. Pressure
 - b. Extra settlement
 - c. Settlement
 - d. Extra pressure
3. The allowable bearing pressure is the maximum pressure the foundation soil is subjected to considering both
 - a. Shear failure and settlement
 - b. Sliding and overturning
 - c. Shear failure and overturning
 - d. Shear failure and sliding
4. The factor of safety for foundations is conventionally equal to
 - a. 1
 - b. 1.6
 - c. 2
 - d. 3
5. The factor of safety for foundations is based on the
 - a. Ultimate bearing capacity and footing pressure
 - b. Net ultimate bearing capacity and net footing pressure
 - c. Ultimate bearing capacity and net footing pressure
 - d. None of the above
6. Which of the following is not an assumption for Terzaghi's Bearing Capacity Theory?
 - a. Soil is homogeneous and isotropic
 - b. Method of superposition is valid
 - c. Footing and ground are horizontal
 - d. Footing carries eccentric loads

7. Generally, the settlement occurring in punching failure is -----the settlement in local shear failure
- Lower than
 - Greater than
 - Equal to
 - Almost equal to
8. A 3.4 m retaining wall is eccentrically loaded, with the force resultant acting at 1.5m from the left end. What is the eccentricity?
- 0.2 m
 - 1.9 m
 - 0.4 m
 - 2.27 m
9. If the vertical component of the resultant in Question 8 is 500 kN, what is the minimum base pressure?
- 83.56 kN at left end
 - 83.56 kN at right end
 - 95.16 kN at left end
 - 95.16 kN at right end
10. When a machine operates at a frequency of 200 Hz (cycles per sec), the period is
- 50 sec
 - 0.50 sec
 - 0.005 sec
 - 0.05 sec
11. A rigid block foundation has degrees of freedom
- 5
 - 6
 - 3
 - 2
12. Terzaghi's bearing capacity theory is applicable to
- Shallow foundations
 - Hollow foundations
 - Deep foundations
 - Amorphous foundations
13. A sand with an angle of friction of 26° will have an active earth pressure coefficient of
- 0.52
 - 0.25
 - 0.33
 - 0.39
14. Groundwater is considered to be "far below foundation level" when the distance from the bottom of the foundation to the groundwater level...
- is equal to the depth of foundation
 - is less than the width of foundation
 - is greater than the width of foundation
 - less than the depth of foundation
15. When water is at foundation level, the factor of safety is
- Lower than water at the surface
 - Greater than water far below foundation
 - Equal to 3
 - Lower than water far below foundation

16. For stability, the base resultant of retaining walls must fall within
- The centre of footing
 - The middle third of footing
 - The left third of footing
 - The right third of footing
17. The cooperating mass of soil of a machine foundation is the soil that
- Supports the foundation
 - Vibrates with the foundation
 - Consolidates under the foundation
 - None of the above
18. When the active earth pressure coefficient of a soil is 0.40, then the angle of friction to one decimal place will be
- 25.4°
 - 42.3°
 - 36000000.5°
 - 40.8°
19. The reduction factor of rock parameters from intact rock to rock mass depends on
- RQD
 - UCS
 - RMR
 - Point Load Index
20. What is one of the consequences of resonance?
- High temperature
 - Excessive Settlement
 - Excessive amplitude of vibration
 - Answer

SECTION B

ANSWER ANY TWO QUESTIONS

21. A strip footing 3 m wide is founded at a depth of 2 m below ground surface in a soil with cohesion of 40 kN/m² and angle of shearing resistance of 30°, (for which $N_c = 18.99$ $N_\gamma = 8.31$ and $N_q = 4.39$). The water table is far below foundation level. The moist unit weight of the soil above the water table is 17 kN/m³ and 19 kN/m³ when saturated.
- Determine the ultimate bearing capacity of the soil **(5 marks)**
 - Determine the net bearing capacity **(5 marks)**
 - Calculate the allowable bearing pressure assuming a factor of safety of 3. **(5 marks)**
 - Suppose the groundwater rises to the ground level, what will be the allowable bearing pressure? **(5 marks)**
 - If the soil were cohesionless ($c = 0$) what would be the percentage reduction in the ultimate and net bearing capacities? **(5 marks)**

22. Details of a cantilever retaining wall are shown in Fig Q22, the water table being below the base of the wall. The unit weight of the backfill is 17.25 kN/m^3 and a surcharge pressure of 10 kN/m^2 acts on the surface as shown in the figure. The shear strength parameters of the backfill are $c' = 0$ and $\phi' = 35^\circ$. The angle of friction between the base and the foundation soil is 27° and the unit weight of the concrete is 22.5 kN/m^3

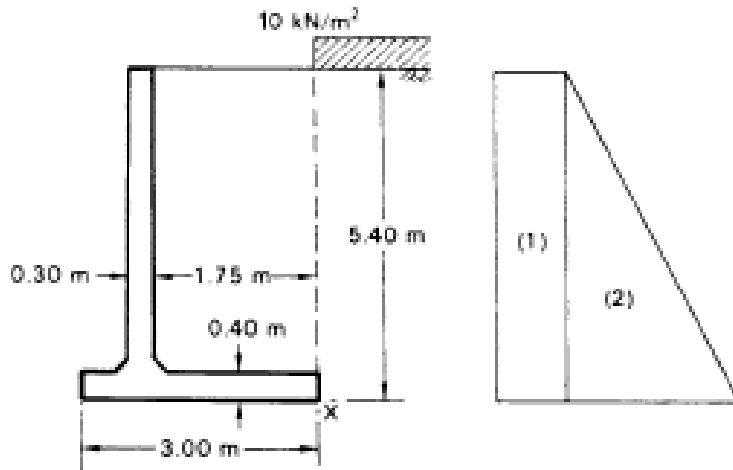

Figure Q 22

- Calculate the horizontal thrust on the wall **(6 marks)**
- Calculate the total vertical force on the foundation soil **(8 marks)**
- Determine the factor of safety against sliding **(5 marks)**
- What is one main advantage of this type of retaining wall? **(6 marks)**

23. Discuss the significance of earthquakes in the design of geotechnical structures. **(25 marks)**

Examiners: E. M. Buaba/Assoc Prof M. Affam