



UNIVERSITY OF MINES AND TECHNOLOGY, TARKWA
SECOND SEMESTER EXAMINATIONS, MAY 2018

COURSE NO : **CE, EL 162**

Unihubgh.com

COURSE NAME: **CIRCUIT THEORY**

SECTION A

Attempt all questions in this section. For each question, write the letter corresponding to the correct answer in your answer sheet provided.

- The switch in the circuit shown in Figure 1 has been moved from position *a* to position *b* at time $t = 0$. The assumption that the capacitor becomes an open circuit at $t = 0$ holds true ____
 - If the switch had stayed in position *a* for a long time ($t = \infty$)
 - If the switch had stayed in position *a* for a short time ($t = 0$)
 - Only when resistors are not in the circuit
 - Only when resistors are present in the circuit

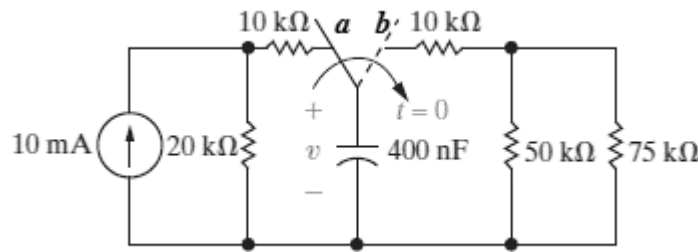

Figure 1 Circuit Diagram for Question 1

- The Norton's equivalent impedance external to the terminals *a* and *b* of the network shown in Figure 2 is
 - 23Ω
 - 9Ω
 - 8Ω
 - 6Ω

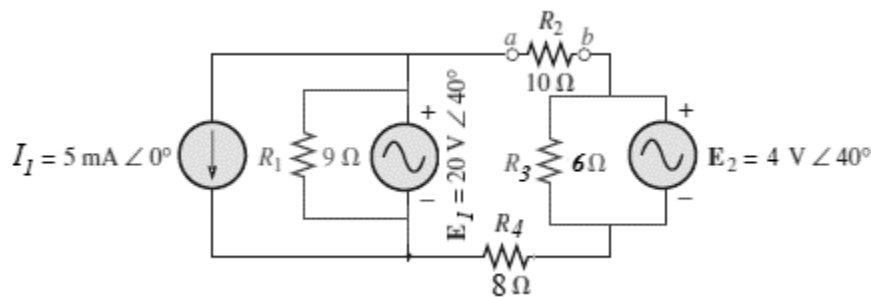
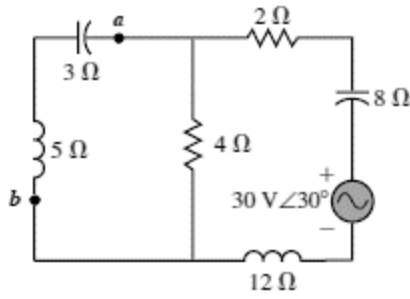

Figure 2 Circuit Diagram for Question 2

- Convert into $z = 4 + j4$ into polar form
 - $z = 16 \angle 90^\circ$
 - $z = 8 \angle 45^\circ$
 - $z = 8 \angle 90^\circ$
 - $z = 4\sqrt{2} \angle 45^\circ$

4. When two or more circuit elements are connected in series
- The currents flowing through them are equal
 - The voltage drops across them are equal
 - The power dissipated by each of them is the same
 - The energy stored in each of them is zero Joules
5. The impedance of a resistor R connected to a source at angular frequency ω is
- $Z = jR$
 - $Z = j\omega R$
 - $Z = R$
 - $Z = 1/R$
6. In a series-parallel circuit, any two elements in series must ____
- Have the same voltage drop across them
 - Have the same impedance
 - Be close to each other
 - Be in the same current path
7. The T-equivalent z -parameter circuit of a two-port network exists if the network is
- Reciprocal
 - Non-reciprocal
 - Linear
 - Non-linear
8. Convert the voltage source in Figure 3 (a) to a current source.
- $I = 60\sqrt{5} \text{ A } \angle 30^\circ$
 - $I = 3\sqrt{5} \text{ A } \angle -33.43^\circ$
 - $I = 4\sqrt{2} \text{ A } \angle 0^\circ$
 - $I = 2\sqrt{5} \text{ A } \angle 93.43^\circ$
9. Use your converted circuit to determine the Norton's equivalent current I_N at terminals **a** and **b**.
- $I_N = 60\sqrt{5} \text{ A } \angle 30^\circ$
 - $I_N = 3\sqrt{5} \text{ A } \angle -33.43^\circ$
 - $I_N = 4\sqrt{2} \text{ A } \angle 0^\circ$
 - $I_N = 2\sqrt{5} \text{ A } \angle 93.43^\circ$
10. For the circuit of Figure 3 (b) determine the current I .
- $I = 21.6 \text{ A } \angle 66.3^\circ$
 - $I = 11.3 \text{ A } \angle 17^\circ$
 - $I = 7.4 \text{ A } \angle 72.51^\circ$
 - $I = -2 \text{ A } \angle 90^\circ$
11. For the circuit of Figure 3 (b) find Thevenin's Equivalent impedance external to terminals **a** and **b**
- $Z_{Th} = 4 \Omega \angle 90^\circ$
 - $Z_{Th} = 2 \Omega \angle 90^\circ$
 - $Z_{Th} = 10 \Omega \angle 53.13^\circ$
 - $Z_{Th} = 6.4 \Omega \angle 41^\circ$



(a)

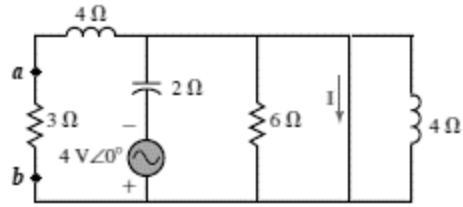

(b)

Figure 3 Circuit Diagrams for (a) Question 4 (b) Question 6

12. For Figure 3 (a), determine the total impedance with respect to the voltage source
- $2.8 + j5.6 \Omega$
 - $4.2 - j1.8 \Omega$
 - $-j6.3 \Omega$
 - $3.6 - j1.5 \Omega$
13. In Figure 4, the controlling current I_I is 80 mA. Find the current I in the circuit.
- 3.67 A
 - 2.67 A
 - 1.67 A
 - 0.67 A

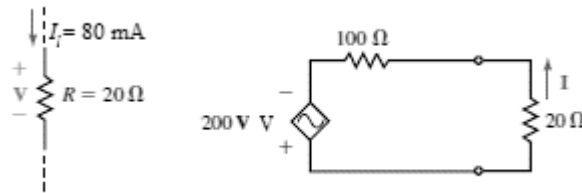

Figure 4 Circuit Diagrams for Question 8

14. For high efficiency of transfer of power, internal resistance of the source should be ____ load resistance
- Equal to
 - Less than
 - Greater than
 - Supplementary to
15. For maximum transfer of power, internal resistance of the source should be ____ load resistance
- Equal to
 - Less than
 - Greater than
 - Supplementary to

A two -port network is an electrical circuit with **-16-** terminal pairs, called ports, where input and output values are accessed. The current entering one terminal pair leaves through the other, as such the net current entering the port is **-17-**. The study of two-port networks is useful for a number of reasons. First, it would be difficult to analyze circuits in situations where only **-18-** are accessible. Furthermore, once the port **-19-** of a two-port network are determined, it is easy to find the responses of the circuit for different input sources or output loads.

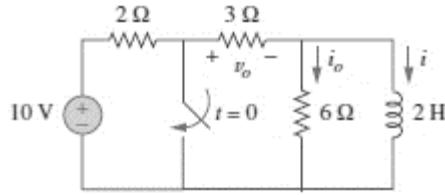

Figure 5 Circuit for Questions 19 and 20

31. A capacitor and an inductor having capacitive and inductive reactances as 8Ω and 6Ω respectively are connected in series. The resulting impedance will be
 A. 14Ω B. 2Ω C. $j14 \Omega$ D. $-j2 \Omega$
32. The equivalent impedance if the capacitor and inductor referred to in Question 18 are connected in parallel will be
 A. $j24 \Omega$ C. $j8 - 8 \Omega$
 B. $-j6.4 \Omega$ D. $j14 \Omega$
33. The equivalence of the voltage $10 \text{ V} \angle 30^\circ$ in rectangular form.
 A. $5\sqrt{3} + j5 \text{ V}$ C. $2\sqrt{2} + j4 \text{ V}$
 B. $5 + j5\sqrt{3} \text{ V}$ D. $10 + j30 \text{ V}$
34. The switch in the circuit shown in Figure 6 has been in position **a** for a long time. At $t = 0$ the switch moves instantaneously to position **b**.
35. Find the initial current flowing through the inductor $i_L(0)$
 A. 45 A B. 60 A C. 3 A D. 4 A
36. What is the final current $i_L(\infty)$ flowing through the inductor at $t = \infty$?
 A. 45 A B. 60 A C. 3 A D. 4 A
37. The current $i_L(t)$ flowing through the inductor at any time $t > 0$ is
 3. $60 - 4e^{-400t}$ 5. $45 - 41e^{-250t}$
 4. $45 - 41e^{-400t}$ 6. $60 - 4e^{-250t}$

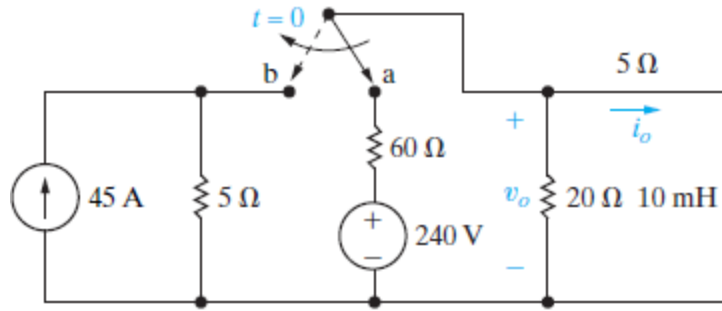

Figure 3 Circuit for (a) Question 4 and (b) Question 5

38. If the voltage drop across a $300 \mu\text{F}$ capacitor is $60e^{-400t} \text{ V}$, then the current flowing through the capacitor is
- | | |
|------------------------------|-----------------------------|
| A. $7.2e^{-400t} \text{ A}$ | C. $8e^{-400t} \text{ mA}$ |
| B. $1.8e^{-400t} \text{ mA}$ | D. $1.8e^{-400t} \text{ A}$ |
39. As the supply frequency increases, the impedance of a capacitor _____
- | | |
|--------------|---------------------|
| A. Decreases | C. Fluctuates |
| B. Increases | D. Remains the same |
40. A voltage controlled current source gives out constant _____ whose value is determined by _____ elsewhere.
- | | |
|---------------------|---------------------|
| A. Current, current | C. Voltage, current |
| B. Voltage, voltage | D. Current, voltage |

SECTION B

Attempt **ONLY TWO** questions in this section. Each question carries equal marks. Answer the questions in your answer booklet.

Question 1 (20 marks)

The switch in the circuit shown in Figure 1(a) has been in position *a* for a long time. At $t = 0$, the switch moves to position *b*.

Determine

- a) The initial voltage drop across the capacitor $v_c(0)$ [5 Marks]
- b) The final voltage on the capacitor $v_c(\infty)$ [5 Marks]
- c) The expression for the capacitor's voltage $v_c(t)$ for time $t \geq 0$ [5 Marks]
- d) Use successive source transformation to find the current I_3 in the circuit of Figure 1(b) [5 Marks]

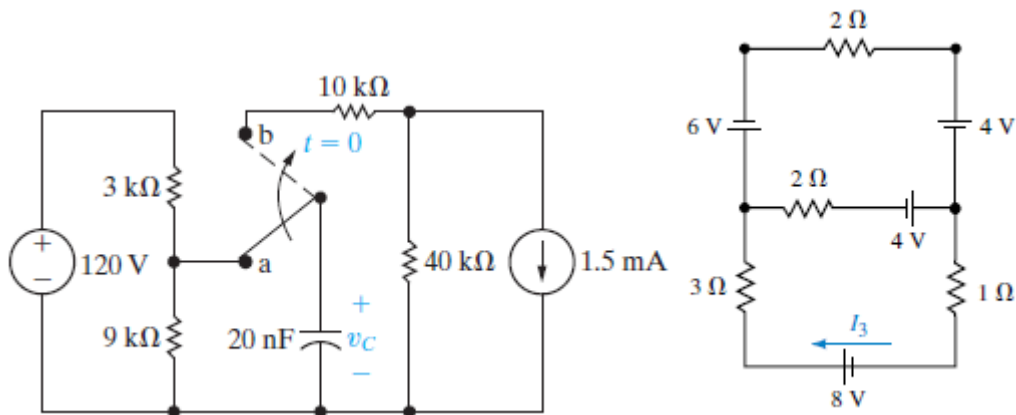

Figure 1 Circuit Diagram for Questions (a) 1 a)- c) and (b) 1d)

Question 2 (20 marks)

Consider the circuit of Figure 2:

- a) Determine the y-parameters of the circuit [11 Marks]
- b)
 - i. State whether the network is reciprocal [2 Marks]
 - ii. Give one reason for your answer in b) above [2 Marks]

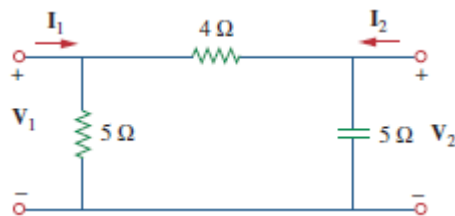

Figure 2 Circuit Diagram for Question 2 a) and b)

c) Simplify the following (you can leave your answer in polar or rectangular form): [5 Marks]

i) $\frac{2-j4}{j}$ ii) $\frac{2}{j} \times 4 \angle 45^\circ$ iii) $2 + j4 + 4 \angle 60^\circ$ iv) $\frac{j30}{j2 \times (-j5)}$ v) $\frac{3-j}{2 \angle 45^\circ}$

Question 3 (20 marks)

- a) Determine the current I_1 flowing through resistor R_1 in the circuit of Figure 3 (b) [6 Marks]
- b) For the circuit of Figure 4, find the load impedance, Z_L , needed to ensure that the load receives maximum power. [8 Marks]
- c) Determine the maximum power to the load [6 Marks]

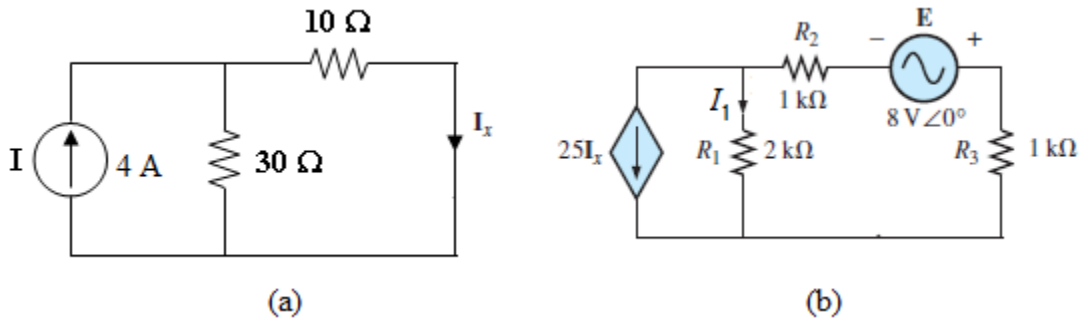

Figure 3 Circuit Diagram for Problem 3

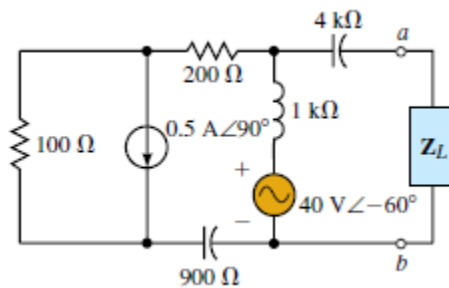

Figure 4 Circuit Diagram for Problem 3